

GAMMA 3P



TS 1C



TS 2C



RPM	CODICE CODE	MODELLO MODEL	PORTATA FLOW				PRESSIONE PRESSURE		POTENZA POWER		PESO WEIGHT	PRESA DI FORZA SHAFT TYPE
			NOM.									
			l/min	GPM	l/min	GPM	bar	PSI	HP	kW	Kg	
600	838200	GAMMA 85 TS 1C	84.8	22.4	83.0	21.9	60	870	12.8	9.5	37.6	TS 1C - 35 mm 1 3/8 Scanalato / Splined
	838100	GAMMA 85 TS 2C	84.8	22.4	83.0	21.9	60	870	12.8	9.5	37.8	
	838700	GAMMA 105 TS 1C	107.4	28.4	105.0	27.7	60	870	16.1	12.0	37.6	TS 2C - 1 3/8 Scanalato / Splined 1 3/8 Scanalato / Splined
	838600	GAMMA 105 TS 2C	107.4	28.4	105.0	27.7	60	870	16.1	12.0	37.8	
	839200	GAMMA 125 TS 1C	134.3	35.5	131.0	34.6	60	870	20.2	15.0	37.6	
	839100	GAMMA 125 TS 2C	134.3	35.5	131.0	34.6	60	870	20.2	15.0	37.8	

Dimensioni d'ingombro (mm) - Overall Dimensions (mm)

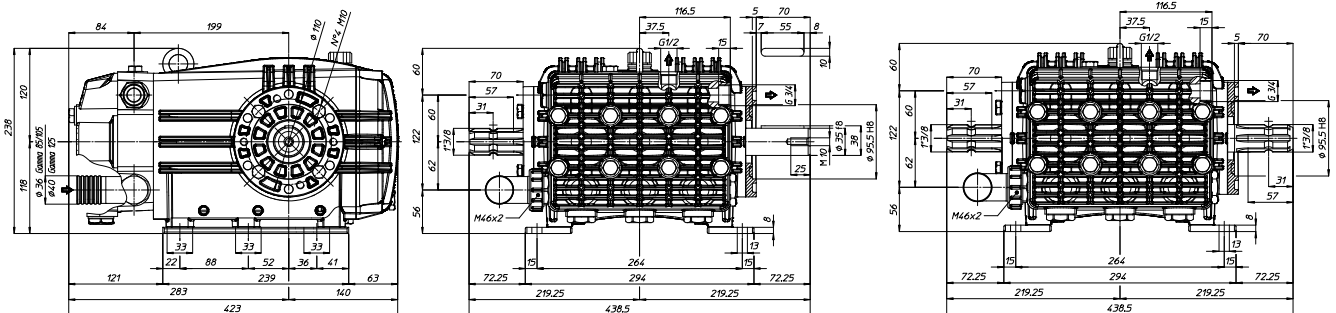

TS 1C

TS 2C